

MIL-C-14806A
NOTICE 1
15 May 1987

MILITARY SPECIFICATION
COATING, REFLECTION REDUCING
FOR INSTRUMENT COVER GLASSES AND LIGHTING WEDGES

MIL-C-14806A dated 1 May 1974, has been reviewed and determined to be valid for use in acquisition.

Custodians:

Army - AR
Navy - AS
Air Force - 11

Preparing activity:

Army - AR

Review activities:

Army - AV
Navy - OS
Air Force - 99

User activities:

Army - MI

AMXC N/A

DISTRIBUTION STATEMENT A.

FSC 6650

Approved for public release; distribution is unlimited.

MIL-C-14806A
AMENDMENT 2
1 May 1974
SUPERSEDING
AMENDMENT 1
14 December 1973

MILITARY SPECIFICATION
COATING, REFLECTION REDUCING, FOR
INSTRUMENT COVER GLASSES AND LIGHTING WEDGES

This amendment forms a part of Military Specification MIL-C-14806A, dated 12 June 1969 and is approved for use by all Departments and Agencies of the Department of Defense.

Paragraph 3.4: Delete and substitute:

"3.4 Specular reflectance.- When applied to substrate materials having indices of refraction within the range of 1.47-1.55 the specular reflectance from each coated surface shall not exceed the following limits for energy incident on the surface at an angle within the range 0-15 degrees inclusive and at an angle of 30 degrees:

<u>Wavelength Range</u> <u>(Nanometers)</u>	<u>Maximum Reflectance (%)</u> <u>(at any wavelength within</u> <u>specified spectral range)</u>	
	<u>0° to 15° incl</u>	<u>30°</u>
440-460	0.55	--
460-660	0.45	--
660-675	0.55	--
425-460	----	1.0
460-620	----	0.7
620-665	----	1.0"

Section 6: Add:

"6.6 International standardization.- Certain provisions (paragraphs 3.4, 3.5, 3.6, 3.7, 3.8 and 3.9) of this specification are the subject of international standardization agreement (ASCC AIR STD 10/61, Coating, Reflection Reducing for Aircraft Station Displays). When amendment, revision, or cancellation of this publication is proposed which will affect or violate the international agreement concerned, the preparing activity will take appropriate reconciliation action through international standardization channels including departmental standardization offices, if required."

MIL-C-1486A
AMENDMENT 2

Custodians:

Army - MU
Navy - AS
Air Force - 11

Preparing activity:

Army - MU

Review activities:

Army - MU, AV
Navy - AS, OS
Air Force - 11, 17, 71

Project No. 6650-0081

User activities:

Army - WC, MI
Navy - SH
Air Force - None
DSA - DM

MIL-C-14806A
12 June 1969

SUPERSIDING
MIL-C-14806
27 May 1968

MILITARY SPECIFICATION

COATING, REFLECTION REDUCING, FOR INSTRUMENT COVER GLASSES AND LIGHTING WEDGES

This specification is mandatory for use by all Departments and Agencies of the Department of Defense.

1. SCOPE

1.1 This specification covers reflection reducing coatings applied to substrate material having indices of refraction within the range of 1.47 to 1.55 to be used as instrument cover glasses and lighting wedges herein referred to as optical elements.

2. APPLICABLE DOCUMENTS

2.1 The following documents, of the issue in effect on date of invitation for bids or request for proposal, form a part of this specification to the extent specified herein.

SPECIFICATIONS

Military

MIL-E-12397	Eraser, Rubber-Pumice for Testing Coated Optical Elements
MIL-O-13830	Optical Components for Fire Control Instruments; General Specification Governing the Manufacture, Assembly and Inspection of

STANDARDS

Military

MIL-STD-105	Sampling Procedures and Tables for Inspection by Attributes
MIL-STD-810	Environmental Test Methods
MIL-STD-1241	Optical Terms and Definitions

(Copies of specifications, standards, drawings, and publications required by suppliers in connection with specific procurement functions should be obtained from the procuring activity or as directed by the contracting officer).

3. REQUIREMENTS

3.1 Optical terms and definitions.- Terms and definitions peculiar to the general field of optics as used herein are defined in MIL-STD-1241.

3.2 Coated area.- Unless otherwise specified, optical elements shall be coated over their entire effective aperture except for an allowable uncoated holding area as shown in the table below.

<u>Diameter or Maximum Diagonal Dimension of Optical Element</u>	<u>Max Width of Uncoated Area</u>
0 - 1.5"	0.030"
1.5 - 2.5"	0.040"
2.5 - 3.5"	0.050"
3.5 - 5.0"	0.060"
5.0 - 7.0"	0.100"

3.3 Cemented and bonded surfaces.- An optical element face or portion thereof which is to be cemented or bonded to another surface or portion thereof shall not be coated on the area to be cemented or bonded.

3.4 Specular reflectance.- When applied to substrate materials having indices of refraction within the range of 1.47 - 1.55 the specular reflectance from each coated surface shall not exceed the following limits for energy incident on the surface at an angle within the range 0 - 15 degrees inclusive and at an angle of 30 degrees:

<u>Wavelength Range Nanometers</u>	<u>Reflectance % Maximum For Angle of Incidence Shown</u>	
	<u>0° to 15° incl</u>	<u>30°</u>
440 - 660	0.6 Abs.	
440 - 635		1.0 Abs.
415 - 685	0.4 Avg.	0.5 Avg.
490 - 605	0.4 Avg.	0.5 Avg.

3.5 Light loss.- Within the wavelength range 425 to 700 nanometers, light loss (absorbance plus (+) diffuse reflectance) in the coating shall not exceed the following limits per surface unless otherwise specified (see 6.2):

Maximum average loss	0.5%
Maximum absolute loss	2.0%

3.6 Coating quality.- The coating shall be uniform in quality and condition, clean, smooth, and free from foreign materials, and from physical imperfections and optical imperfections as follows:

3.6.1 The coating shall show no evidence of flaking, peeling or blistering.

3.6.2 The coating shall not contain blemishes such as discolorations, stains, smears and streaks.

3.6.3 The coating shall show no evidence of a cloudy or hazy appearance.

3.6.4 Unless otherwise specified, the coating shall meet the following scratch and dig requirements. Coating defects shall be counted in addition to those allowed by the substrate specification.

Lighting wedges or light piping glass	- 40-20	per MIL-O-13830
Cover glass for lighted instruments	- 60-20	per MIL-O-13830
Cover glass for unlighted instruments	- 80-50	per MIL-O-13830

Coating spatter shall be counted as a dig or inclusion.

3.6.5 Pinholes in the coated surface shall not exceed twice the allowable dig size. Unless otherwise specified, pinhole distribution shall be ignored.

3.7 Abrasion resistance.- There shall be no visible damage to the coated surface when rubbed with an eraser conforming to MIL-E-12397 under a force of 2 to 2 1/2 lbs.

3.8 Humidity - "B".- Continuous exposure for 24 hours in an atmosphere controlled at 116°F to 124°F and 95 to 100% relative humidity.

3.9 Salt fog.- A 5% solution at a temperature of 95°F for 48 hours.

3.10 Humidity - "C".- Continuous exposure for 48 hours in a controlled atmosphere with a relative humidity ranging between 85 and 95% at temperatures ranging from 82°F to 160°F.

3.11 Environmental.- Coated optical elements shall withstand the following environmental exposures.

3.11.1 High temperature.- Temperature of 160°F for not less than 48 hours.

3.11.2 Low temperature.- Temperature of -65°F for not less than 48 hours.

3.11.3 Temperature shock.- Temperature of 160°F for 4 hours and transferred within 5 minutes into a temperature of -65°F for 4 hours and returned within 5 minutes to 160°F for 4 hours.

3.11.4 Humidity - "A".- Continuous exposure for 240 hours in a controlled atmosphere with a relative humidity ranging between 85 and 95% at temperatures ranging from 82°F to 160°F.

3.11.5 Dust.- A fine sand-laden air with a maximum velocity of 2000 feet per minute for 28 hours.

3.11.6 Fungus.- A mixed spore suspension for 28 days.

4. QUALITY ASSURANCE PROVISIONS

4.1 Responsibility for inspection.- Unless otherwise specified in the contract or purchase order, the supplier is responsible for the performance of all inspection requirements as specified herein. Except as otherwise specified, the supplier may utilize his own facilities or any other facilities suitable for the performance of the inspection requirements specified herein, unless disapproved by the Government. The Government reserves the right to perform any of the inspections set forth in the specification where such inspections are deemed necessary to assure supplies and services conform to prescribed requirements.

4.2 Certification.- Unless actual performance of the tests is specified in the contract (see 6.2), the supplier shall certify product conformance to the requirements of 3.11 for each shipping lot.

4.2.1 Certification testing.- When such testing is required, each of six test parts shall be subjected to the sequence of tests in Table I. Upon completion of the test sequence, the test parts shall be assembled into an appropriate instrument or test device and evaluated. The ability to read the instrument without a substantial reduction in clarity shall be considered evidence of successful completion of the testing. Test procedures are specified in MIL-STD-810.

4.2.2 Certification test samples.- Unless otherwise specified in the contract (see 6.2), certification test samples shall be crown glass of refractive index 1.523 and Abbe number of 58.6, and shall be of such a size and configuration that they can be assembled into an instrument or suitable test device for evaluation.

TABLE I - CERTIFICATION TESTS

<u>Characteristic</u>	<u>Requirement</u>	<u>Test Method</u>
Light Loss	3.5	4.4.5
Temperature - High	3.11.1	MIL-STD-810, Method 501-1
Temperature - Low	3.11.2	MIL-STD-810, Method 502-1
Temperature - Shock	3.11.3	MIL-STD-810, Method 503-1
Humidity "A"	3.11.4	MIL-STD-810, Method 507.1
Salt Fog	3.9	MIL-STD-810, Method 509.1
Dust	3.11.5	MIL-STD-810, Method 510.1
Fungus	3.11.6	MIL-STD-810, Method 508.1

4.3 Inspection provisions.

4.3.1 Final acceptance inspection.- The classification of defects in Table II constitutes the minimum inspection to be performed by the supplier prior to government acceptance or rejection by item or lot.

4.3.1.1 Acceptance and rejection.- Rejected lots shall be screened for all defective characteristics. Removal or correction of defective units and resubmittance of rejected lots shall be in accordance with "Acceptance and Rejection" as specified in MIL-STD-105.

MILITARY SPECIFICATION
COATING, REFLECTION REDUCING
FOR INSTRUMENT COVER GLASSES AND LIGHTING WEDGES

MIL-C-14806A dated 1 May 1974, has been reviewed and determined to be valid for use in acquisition.

Custodians:

Army - AR
Navy - AS
Air Force - 11

Preparing activity:

Army - AR

Review activities:

Army - AV
Navy - OS
Air Force - 99

User activities:

Army - MI

4.3.1.2 Submission of product.- Unless otherwise specified by the contracting officer, inspection lot size, lot formation, and presentation of lots shall be in accordance with "Submission of Product" provisions in MIL-STD-105. A lot will be considered to be a shipping lot (see 6.5).

TABLE II - CLASSIFICATION OF DEFECTS

Level II of Table I with Sampling Plan Table IIA of MIL-STD-105

<u>Class</u>	<u>Requirement</u>	<u>Test Paragraph</u>
<u>Critical:</u> None		
<u>Major:</u> AQL 1.0% defective		
101. Coated Area	3.2	4.4.1
102. Cemented and Bonded Surfaces	3.3	4.4.2
103. Coating Quality	3.6	4.4.3.1, 4.4.3.3, 4.4.3.4, 4.4.3.5

4.3.2 Final acceptance test.- The classification of defects in Table III shall constitute the minimum tests to be performed by the supplier prior to government acceptance or rejection by item or lot.

4.3.2.1 Test samples.- Unless otherwise specified (see 6.2), two (2) test witness pieces of a similar refractive index and surface finish as the parts to be coated and coated in the same evaporation lot (see 6.4) as the parts, shall be subjected to each individual test of Table III. No two (2) test witness pieces need be subjected to more than one test. The test witness pieces shall be placed in the coating chamber such that they represent the whole evaporation lot.

4.3.2.2 Acceptance and rejection.- Failure of any test shall cause the evaporation lot to be rejected. Rejected lots shall be screened for all defective characteristics. Removal and correction of defective units and resubmittance of rejected lots shall be in accordance with "Acceptance and Rejection" as specified in MIL-STD-105.

TABLE III

<u>Characteristic</u>	<u>Requirement</u>	<u>Test Paragraph</u>
201. Humidity "B" and Abrasion	3.8 3.7	4.4.6, 4.4.3.1, 4.4.3.2 4.4.7, 4.4.3.1
202. Reflectance	3.4	4.4.4
203. Salt Fog	3.9	4.4.8, 4.4.3.1
204. Humidity "C"	3.10	4.4.9, 4.4.3.3

4.4 Test methods and procedures

4.4.1 Coated area.- Coated area shall be visually examined to determine conformance to 3.2.

4.4.2 Cemented and bonded surfaces.- Coated area shall be visually examined to determine conformance to 3.3.

4.4.3 Coating quality.- Coated surfaces shall be examined for conformance to 3.6 as follows:

4.4.3.1 The coating shall be examined by both transmission and reflection for evidence of flaking, peeling or blistering. The test method is as shown in Figure I-b. Such evidence shall be cause for rejection.

4.4.3.2 The coating shall be examined by both transmission and reflection for evidence of discoloration, stains, streaks, or smears. The test method is as shown in Figure I-b. When such evidence is found, the blemished area shall be evaluated by specular reflectance. Parts exceeding the requirements of 3.4 shall be rejected.

4.4.3.3 The coatings shall be evaluated as shown in Figure I-c for evidence of cloudy or hazy appearance. Such evidence shall be cause for rejection.

4.4.3.4 The coating shall be examined by transmission as shown in Figures I-a and I-b for pinhole, and scratch and dig requirements. Parts exceeding the requirements specified in 3.6.4 and 3.6.5 shall be rejected.

4.4.3.5 The coating shall be examined by the transmission method for evidence of discoloration, stains, streaks and smears. The test method is as shown in Figure I-b. Such evidence shall be cause for rejection.

4.4.4 Specular reflectance.- To determine conformance to the requirements of 3.4, the test shall be conducted with a calibrated spectrophotometer or a low level reflectometer capable of measuring within the 400 to 700 nanometer wavelength range. The measuring equipment shall be suitably equipped to measure specular reflectance at the angles specified.

4.4.5 Light Loss.- To determine conformance to the requirements of 3.5, this test shall be conducted using a calibrated spectrophotometer capable of measuring within the 400 to 700 nanometer wavelength range. Several elements are scanned in series with the spectrophotometer. The elements may be skewed in the beam, precoating and post coating measurements are compared, reflection losses are extracted and the resulting absorption loss per surface determined.

4.4.6 Humidity - "B".- The test samples shall be placed into an environmentally controlled test chamber at a controlled temperature of $120 \pm 4^{\circ}\text{F}$ and $95\% \pm 5\%$ relative humidity and held for 24 hours minimum. After completion of this test, the parts shall be evaluated for conformance to 3.6.1 and 3.6.2. Following this evaluation, the parts shall be subjected to the abrasion test of 4.4.7.

4.4.7 Abrasion.- The coating shall be tested by rubbing the coated surface with a standard eraser conforming to MIL-E-12397 mounted in the holding device. A force of between 2 and 2 1/2 lbs. shall be applied. Strokes of approximately one inch shall be made if the size of the element permits; smaller strokes for smaller elements. All strokes shall be made on one path for twenty strokes. After completion of this test, the parts shall be evaluated for conformance to 3.6.1.

4.4.8 Salt fog.- The coatings shall be tested as specified in MIL-STD-810, Method 509-I. After completion of this test, the parts shall be evaluated for conformance to 3.6.1.

4.4.9 Humidity - "C".- The coating shall be tested as specified in MIL-STD-810, Method 507-I, except that the test time shall be 48 hours (2 cycles). Upon completion of these tests, the parts shall be evaluated for conformance to 3.6.3.

5. PREPARATION FOR DELIVERY

5.1 Packaging shall be accomplished in a manner to ensure that the coated glasses during shipment and storage, will not be damaged by chipping, abrading or staining.

6. NOTES

6.1 Intended use.- The coatings covered by this specification are applied to the surfaces of optical elements primarily to reduce the intensity of reflected surface light and increase light transmission.

6.2 Ordering data.- Procurement documents should specify the following:

- a. Title, number and date of this specification.
- b. Performance of certification tests if required (see 4.2) and quantity of test parts required (if different than 4.2).
- c. Type and size of certification test parts (if different than 4.2).
- d. Light loss permitted (if different than 3.5).
- e. Number of test samples (if different than 4.3.2.1).

6.3 Abrasion testing device.- A device conforming to Frankford Arsenal Drawing No. D7680606 may be used for the abrasion testing of 4.4.7.

6.4 Evaporation lot.- An "evaporation lot" shall be defined as the group of parts which has the coatings applied at the same time and in the same evaporation chamber.

MIL-C-14806A

6.5 Shipping lot. - A "shipping lot" shall consist of units manufactured under essentially the same conditions and at approximately the same time.

Custodians:

Army - MU
Navy - AS
Air Force - 11

Preparing Activity:

Army - MU

Review Activities:

Army - MU, AV
Navy - AS, OS
Air Force - 11, 17, 26

Civilian Agencies
Interest-DM

User Activities:

Army - WC, MI
Navy - SH
Air Force - None

Project No. 6650-0035

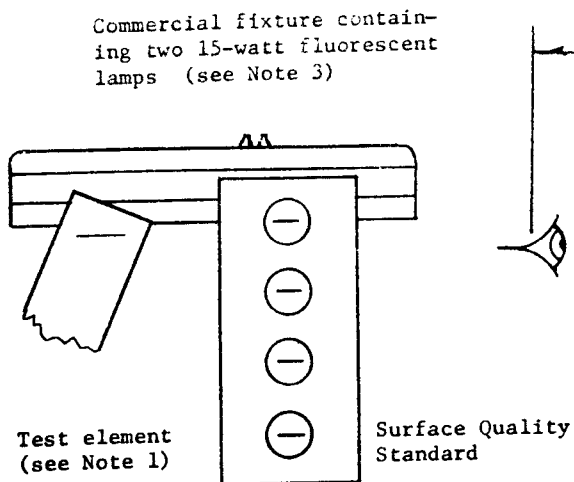

(a)

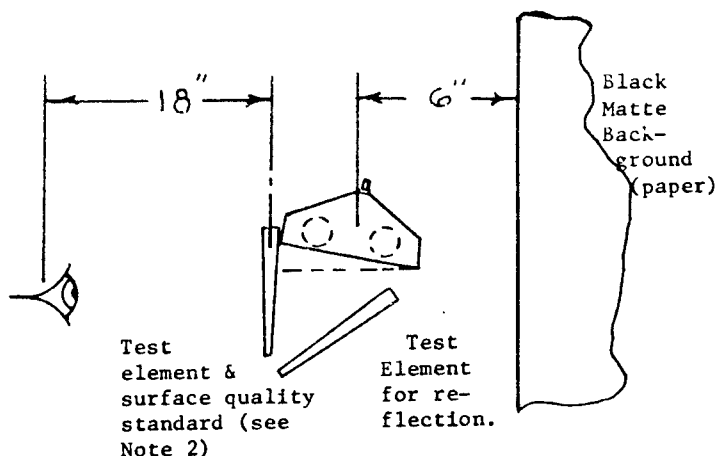

(b)

NOTES:

1. The scratches on the test element shall be aligned parallel to those of the companion surface quality standard.
2. For measuring pinholes, scratches, and digs, both the standard and the element surface are viewed using transmitted light.
3. The only illumination in the test area shall be from the light source used for test.
4. For evaluation of flaking, peeling, blistering, blemishes, and haze, elements shall be checked without the use of scratch and dig standards.

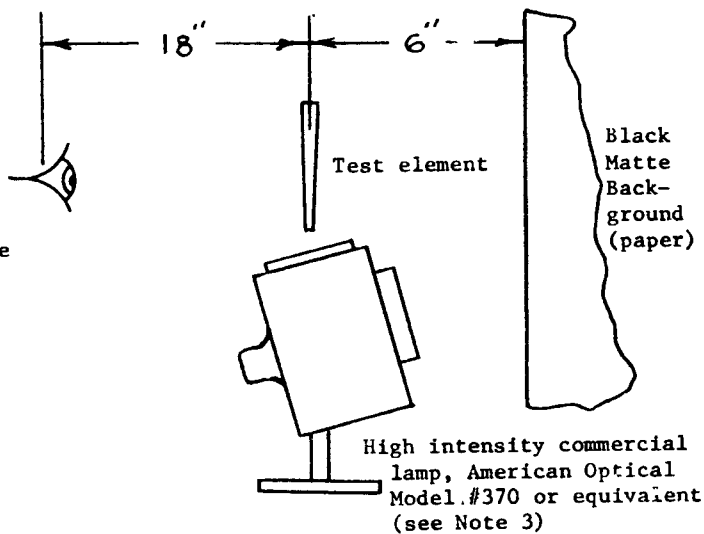

(c)

FIGURE 1